

Model
Dortmund-Kamen



Security level: Class 0 according to EN 1143-1
Fire rating: Fire-protected safes according to EN 15659 LFS 30 P

SPECIAL FEATURE - safe equipped with 200 mm high inner safe and adjustable shelf/shelves below (models 55509-55510 without inner safe, include 2 adjustable shelves with long rifle cut-out instead).

- Suitable for the storage of:
- gun
 - ammunition
 - office documents, office equipment
 - valuables

Description
Dortmund-Kamen series - high security gun safes with light fire - protection.

Body: multi-walled body (62 mm thick)
Door: multi-walled door construction (104 mm thick)
Locking: 4-way locking bolt system - incl. overlapping profile on the hinge side

Standard option
Lock: high security key lock I class VdS with two keys (120 mm)
Boltwork handle: handle, protruding 60mm
Hinges: external
Door opening angle: 180°
Mounting holes: 1 hole in the floor
Colour: RAL 7035 (light grey)

Model
Dortmund-Kamen

Art. No.	Model	Outer dimensions*			Inner dimensions			Door light		Anchoring		Weight Kg	Shelves Number	Weapon brackets Number	Internal safe Height mm
		Height mm	Width mm	Depth mm	Height mm	Width mm	Depth mm	Height mm	Width mm	Bottom number	Backwall number				
55500	Dortmund-Kamen	1550	700	550	1229	576	344	1396	546	1	-	307	-	10	180
55501	Dortmund-Kamen	1550	836	550	1229	712	344	1396	682	1	-	345	-	13	180
55502	Dortmund-Kamen	1706	636	550	1385	512	344	1552	482	1	-	315	1	9	180
55503	Dortmund-Kamen	1706	836	550	1385	712	344	1552	682	1	-	376	1	13	180
55504	Dortmund-Kamen	1806	700	550	1485	576	344	1652	546	1	-	353	2	10	180
55505	Dortmund-Kamen **	1706	950	550	1515	826	344	1515	796	1	-	458	1	15	180 ****
55506	Dortmund-Kamen **	1706	1260	550	1515	1136	344	1515	1106	1	-	557	1	20	180 ****
55507	Dortmund-Kamen **	1806	1200	550	1615	1076	344	1615	1046	1	-	569	2	19	180 ****
55508	Dortmund-Kamen **	1806	1486	550	1615	1364	344	1615	1334	1	-	668	2	24	180 ****
55509	Dortmund-Kamen	1400	520	500	1261	396	294	1246	366	1	-	226	2***	7	-
55510	Dortmund-Kamen	1400	675	500	1261	551	294	1246	521	1	-	260	2***	10	-

* excluding hinges, handles and fittings ** 2-door *** with long rifle cut-out **** double-door inner safe with partition wall



Body: multi-walled body (62 mm thick)



Door: multi-walled door construction (104 mm thick)

Closure options

Standard option



Key lock

Options available against surcharge



Mechanical code lock



Electronic lock



Electronic lock with mechanical emergency (Excl. Art. No. 55509)

Accessories available against surcharge

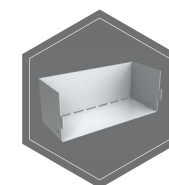

Storage tray

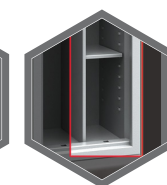

Partition wall with shelves

Alternative options



Left door

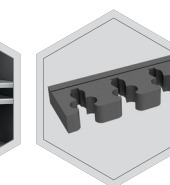

Gun holder (65 mm)

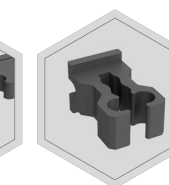

Rubbery gun holder

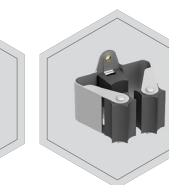

PRAX gun holder



All information concerning weight, color and dimensions are noncommittal and subject to errors and changes. Minor deviations are conditional on the production process. Technical changes, modifications and printing errors reserved. Safes may be top-heavy, during commissioning, please exercise appropriate caution in accordance with the installation guide. Pictograms are not technical description of the product.

The image depicts a sample of a gun safe - **St.Gallen 56402** with additional equipment.



With options **left door** - internal equipment will be located opposite to the standard - the so-called mirror reflection



Option with **partition wall** - the amount of gun holders and the location of the shelves is needed



Gun holder

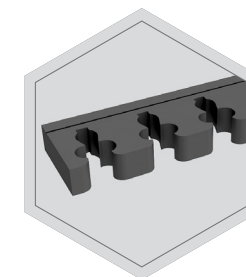

Gun holders with 55 mm span

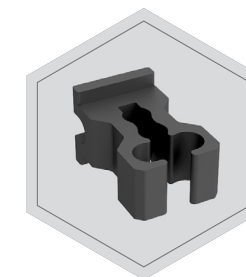

Rubbery gun holders

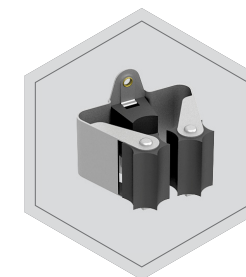

PRAX gun holders

Foam gun holders

Standard foam gun holder with 55 mm span

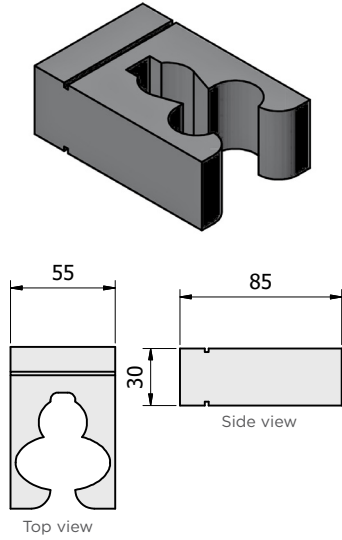

Foam gun holder with 65 mm span

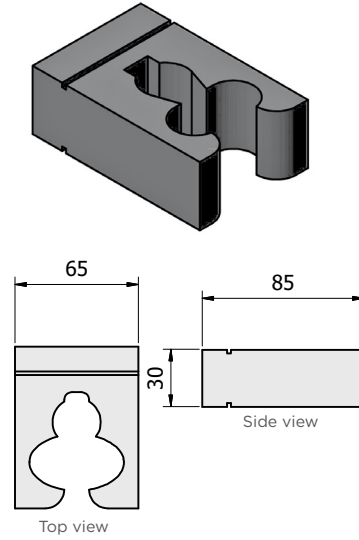

Exemplary assembly of the gun holders on the rail:

⚠ Foam gun holders are assembled as one piece not separately.

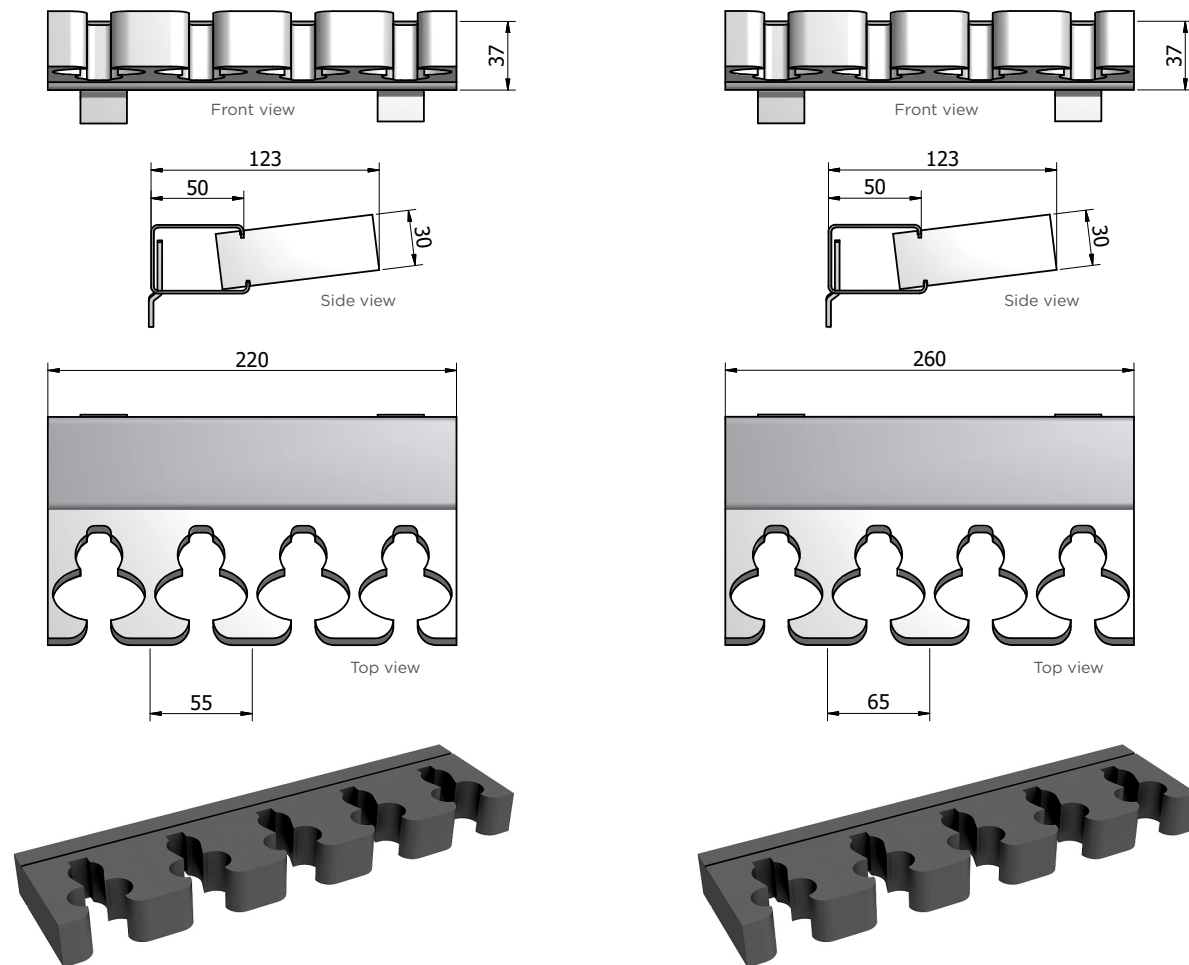

Rubbery gun holders

Rubbery gun holder

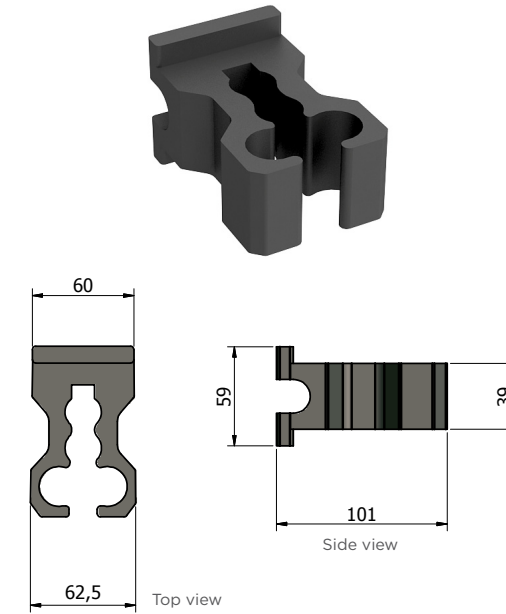

PRAX gun holder

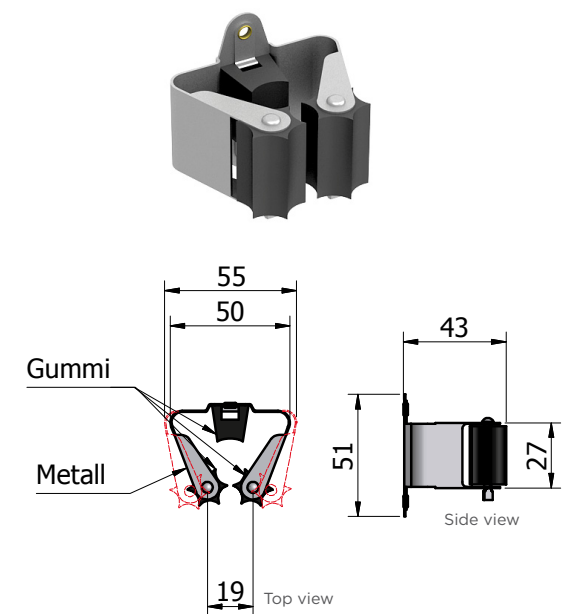

Exemplary assembly of the gun holders on the rail:

⚠ Rubbery gun holders may be assembled on the rail separately, which enables extending of the distance between them. There is a possibility to disassembly particular gun holders. Special rail required.

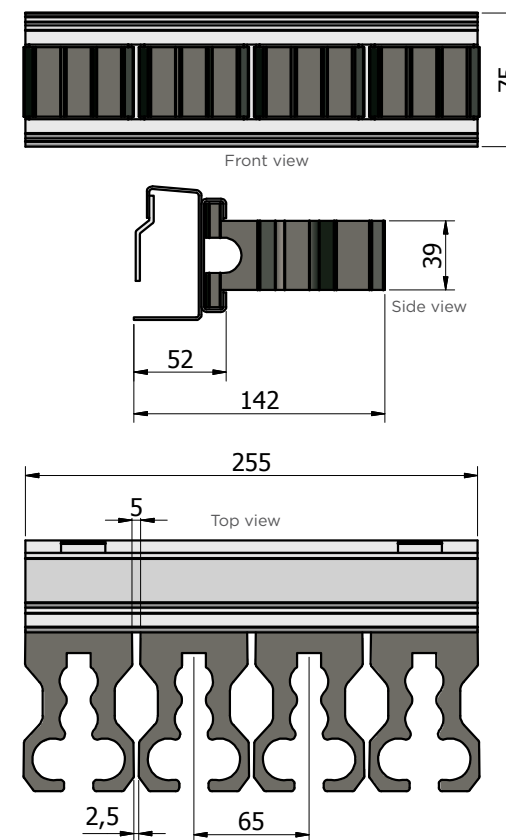

⚠ Gun holders may be screwed to the rail separately, which enables extending of the distance between them.

Special rail required.

